



THE ST350 STRAIN TRANSDUCER HAS BEEN DESIGNED TO QUICKLY AND ACCURATELY MEASURE STRAIN ON A VARIETY OF STRUCTURES IN HARSH FIELD ENVIRONMENTS. THIS 350Ω FULL WHEATSTONE BRIDGE STRAIN TRANSDUCER IS VERY ACCURATE, RUGGED, AND WATERPROOF. PROVIDING ROUGHLY 3.5 TIMES THE OUTPUT OF A TYPICAL FOIL STRAIN GAGE, THESE REUSABLE SENSORS ARE IDEAL FOR MEASURING LIVE-LOAD STRAIN ON STRUCTURES AND CAN BE INSTALLED WITHIN MINUTES IN ALL WEATHER CONDITIONS.

FEATURES

- + Cost effective
- + Installs in 5 minutes or less
- + Reusable, lasts for >10 years
- + Waterproof to 20ft (6 m)
- + Industrial cable, custom lengths
- + Standard millivolt output
- + N.I.S.T traceable calibration

APPLICATIONS

- + Steel
- + Pre-stress/post-tension concrete
- + Reinforced concrete
- + Timber
- + Fiber Reinforced Polymer (FRP)
- + Live-Load testing & monitoring
- + Laboratory testing
- + Fatigue monitoring
- + Tension rod forces

DIMENSIONS

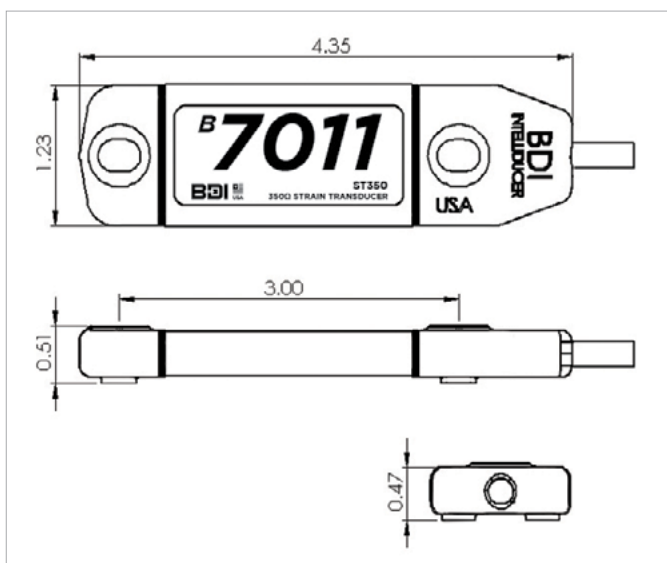

STEEL



CONCRETE

SPECIFICATIONS

MODEL	ST350
TYPE	350Ω
CIRCUIT	Full Wheatstone bridge with 4 active 350Ω strain gages
EXCITATION VOLTAGE	+1.0 to +10.0 V _{dc}
OUTPUT	mV level, ratiometric to Excitation Voltage
OFFSET	< 1.5 mV at time and temperature of calibration
POWER: MAX TYPICAL INTELLIDUCER ¹	300 mW 72 mW @ +5.0 V _{dc} 13 mW @ +5.0 V _{dc}
STRAIN RANGE	±4,000 µε (Calibrated to ±2,000 µε)
FORCE REQUIRED FOR 1000 µε	~17 lb (~76N)
TYPICAL SENSITIVITY	~500 µε/mV _{out} / V _{in}
ACCURACY ²	< ±1%
CALIBRATION	Individually calibrated using N.I.S.T. - traceable automated system. Calibration curve & factor provided
THERMISTOR (OPTIONAL)	3 kΩ - NTC
EFFECTIVE GAGE LENGTH	3.0 in (76.2 mm) [Gage Extensions available for R/C Structures]
CABLE	Custom lead cable length made to order: IC-02-187 [22 AWG 2 shielded pair, drain wire, red PVC jacket] IC-02-250 [22 AWG, 2 shielded pair, drain wire, blue PVC jacket] IC-03-250 [24 AWG, 3 shielded pair, drain wire, black PVC jacket]
HOUSING	Machined 6061 Aluminum Alloy
CORROSION PROTECTION	Hard Anodized Clear (MIL-A-8625 Type III)
WEATHER PROTECTION	Designed to exceed IP67 Optional 100 ft (30 m), waterproofing available
TEMPERATURE RATING ³	-58° to +176 °F (-50° to +80 °C)
SIZE	4.38 in x 1.25 in x 0.50 in (111 mm x 32 mm x 12.7 mm)
WEIGHT	0.19 lb (85 g)
MOUNTING	Through holes for ¼ in (M6) bolts or anchors Reusable mounting tabs (gluing/welding)

¹ Intelliducer connector required with STS Intelliducer data acquisition nodes.

² Accuracy defined at the calibrated 32,000 µε range.

³ Temperature limit based on instrumentation cable operating temperatures, call BDI for wide temperature range cable options.

OPTIONS & ACCESSORIES



Intelliducer Connector - Required for use with STS Intelliducer Nodes, cable is connected and potted for a weatherproof seal.

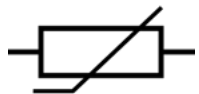

Integrated Thermistor - Temperature range of -55 °C to +220 °C, ±0.5 °C accuracy.



Reusable Mounting Tabs - ¼-20 or M6, zinc plated steel mounting tab.



Tab Jig - Machined aluminum jig for safely attaching mounting tabs to the strain transducer. Includes either 7/16" or M10 end wrench.



Gage Extension - Machined aluminum 24 in (610 mm) gage length extension with 3.0 in (76 mm) increments.



Extension Jig - Aluminum mounting jig for safely attaching gage extensions.

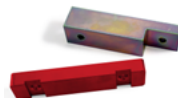

Installation Jigs - Welding or concrete drilling jigs.

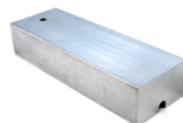

Protective Covers - Insulated aluminum protective covers.