



The World Leader in Vibrating Wire Technology

*48 Spencer Street
Lebanon, NH 03766, USA
Tel: 603•448•1562
Fax: 603•448•3216
E-mail: geokon@geokon.com
<http://www.geokon.com>*

Instruction Manual
Model 4000
(and 4050)
Vibrating Wire Strain Gage



No part of this instruction manual may be reproduced, by any means, without the written consent of Geokon, Inc.

The information contained herein is believed to be accurate and reliable. However, Geokon, Inc. assumes no responsibility for errors, omissions or misinterpretation. The information herein is subject to change without notification.

Copyright © 1981, 1996, 2004, 2005, 2008, 2009, 2010, 2012, 2013, 2014 by Geokon, Inc.
(Doc Rev Y, 12/14)

Warranty Statement

Geokon, Inc. warrants its products to be free of defects in materials and workmanship, under normal use and service for a period of 13 months from date of purchase. If the unit should malfunction, it must be returned to the factory for evaluation, freight prepaid. Upon examination by Geokon, if the unit is found to be defective, it will be repaired or replaced at no charge. However, the WARRANTY is VOID if the unit shows evidence of having been tampered with or shows evidence of being damaged as a result of excessive corrosion or current, heat, moisture or vibration, improper specification, misapplication, misuse or other operating conditions outside of Geokon's control. Components which wear or which are damaged by misuse are not warranted. This includes fuses and batteries.

Geokon manufactures scientific instruments whose misuse is potentially dangerous. The instruments are intended to be installed and used only by qualified personnel. There are no warranties except as stated herein. There are no other warranties, expressed or implied, including but not limited to the implied warranties of merchantability and of fitness for a particular purpose. Geokon, Inc. is not responsible for any damages or losses caused to other equipment, whether direct, indirect, incidental, special or consequential which the purchaser may experience as a result of the installation or use of the product. The buyer's sole remedy for any breach of this agreement by Geokon, Inc. or any breach of any warranty by Geokon, Inc. shall not exceed the purchase price paid by the purchaser to Geokon, Inc. for the unit or units, or equipment directly affected by such breach. Under no circumstances will Geokon reimburse the claimant for loss incurred in removing and/or reinstalling equipment.

Every precaution for accuracy has been taken in the preparation of manuals and/or software, however, Geokon, Inc. neither assumes responsibility for any omissions or errors that may appear nor assumes liability for any damages or losses that result from the use of the products in accordance with the information contained in the manual or software.

TABLE of CONTENTS

1. INTRODUCTION	1
2. GAGE INSTALLATION -GENERAL	2
2.1 PRELIMINARY TESTS.....	2
2.2 ARC WELDING THE MOUNTING BLOCKS TO STEEL SURFACES – USING THE SPACER BAR.....	2
2.3 ARC WELDING SEQUENCE.....	3
2.4 SETTING THE STRAIN GAGE	3
2.5 INITIAL READINGS	4
3. GAGE PROTECTION	4
3.1 PROTECTION FROM CORROSION	4
3.2 PROTECTION FROM DIRECT SUNLIGHT AND RAPID CHANGES IN AMBIENT TEMPERATURE.....	4
3.3 PROTECTION FROM MECHANICAL DAMAGE.....	4
3.4 CABLE AND CONNECTOR PROTECTION.....	5
3.5. LIGHTNING PROTECTION	6
4. GAGE LOCATION	7
4.1. END EFFECTS	7
4.2. WELDING EFFECTS.....	7
4.3 BENDING MOMENTS.....	7
5. SPECIAL APPLICATIONS	11
5.1 INSTALLATION ON DRIVEN STEEL PILES.....	11
5.2 INSTALLATION ON STEEL OR CONCRETE SURFACES USING EPOXY CEMENTS.....	12
5.2.1 Concrete Surfaces:.....	12
5.2.2 Steel Surfaces:.....	12
5.3 INSTALLATION ON CONCRETE SURFACES USING ANCHOR STUDS.....	13
6. TAKING READINGS	13
6.1. OPERATION OF THE GK-403 READOUT BOX.....	14
6.2 OPERATION OF THE GK-404 READOUT BOX.....	14
6.3 OPERATION OF THE GK-405 READOUT BOX.....	15
6.4. MEASURING TEMPERATURES	15
7. DATA INTERPRETATION	16
7.1 CONVERSION OF THE READINGS TO STRAIN CHANGES.....	16
7.2 CONVERTING STRAINS TO STRESSES.....	16
8. TROUBLESHOOTING	17
APPENDIX A - SPECIFICATIONS	18
A.2 THERMISTOR (SEE APPENDIX C ALSO)	18
APPENDIX B - THEORY OF OPERATION	19
APPENDIX C - THERMISTOR TEMPERATURE DERIVATION	21
APPENDIX D - MODEL 4050 SPECIAL INSTRUCTIONS (12” GAGE LENGTH)	22
APPENDIX E - MEASUREMENT OF, AND CORRECTION FOR, TEMPERATURE EFFECTS	23
APPENDIX F - TEMPERATURE CORRECTION WHEN USED ON CONCRETE	24
APPENDIX G - CALCULATION OF AXIAL LOADS AND BENDING STRAINS FROM THREE STRAIN GAGES, AT 60 DEGREES, ON A CIRCULAR PIPE	25
APPENDIX H - TWO STRAIN GAGES MOUNTED ONE ABOVE THE OTHER	26

LIST of FIGURES, TABLES and EQUATIONS

FIGURE 1 - MODEL 4000 VIBRATING WIRE STRAIN GAGE	1
FIGURE 2 - SPACING JIG	2
FIGURE 3 - WELDING SEQUENCE FOR THE MOUNTING BLOCKS	3
FIGURE 4 - TYPICAL COVER PLATE INSTALLATION	5
FIGURE 5 - LIGHTNING PROTECTION SCHEME	6
FIGURE 6A - STRAIN GAGES MOUNTED ON CENTRAL WEB MEASURES AXIAL STRAIN AND BENDING MOMENTS ABOUT BOTH XX AND YY AXES	8
EQUATION 1 - AXIAL STRESS CALCULATION	8
EQUATION 2 - STRESS DUE TO BENDING ON AXIS YY	8
EQUATION 3 - STRESS DUE TO BENDING ON AXIS XX	8
EQUATION 4 - MAXIMUM STRESS	8
FIGURE 6B - STRAIN GAGES MOUNTED ON FLANGES (NOT RECOMMENDED ON TUNNEL ARCHES)	9
FIGURE 6C - AXIAL STRAIN MEASUREMENT AND BENDING MOMENT ABOUT YY AXIS ONLY.	9
FIGURE 6D - AXIAL STRAIN AND BENDING MOMENTS ABOUT XX AXIS	10
FIGURE 6E – AXIAL STRAIN AND BENDING MOMENT AROUND AXIS XX (NOT RECOMMENDED)	10
FIGURE 7 PROTECTION ON DRIVEN PILES	11
FIGURE 8 INSTALLATION USING EPOXY	12
FIGURE 9 - INSTALLATION ON CONCRETE USING GROUTABLE ANCHORS	13
TABLE 1 - STRAIN GAGE READOUT STRAIN RANGES	13
EQUATION 5 - APPARENT STRAIN CALCULATION	16
EQUATION C-1 CONVERT THERMISTOR RESISTANCE TO TEMPERATURE.....	21
TABLE C-1 THERMISTOR RESISTANCE VERSUS TEMPERATURE	21

1. INTRODUCTION

The Geokon Model 4000 Vibrating Wire Strain Gage is intended primarily for long-term or short term strain measurements on structural steel members such as tunnel linings, arches, struts, piles, sheet piling, etc.

The primary means of attachment is by conventional arc welding, but they may also be used to monitor strain changes on concrete or rock surfaces using anchors grouted into boreholes.

Strains are measured using the vibrating wire principle: a length of steel wire is tensioned between two mounting blocks that are welded to the steel surface being studied. Deformations (i.e., strain changes) of the surface will cause the two mounting blocks to move relative to one another, thus altering the tension in the steel wire. The tension in the wire is measured by plucking the wire and measuring its resonant frequency of vibration. The wire is plucked, and its resonant frequency measured, by means of an electromagnetic coil positioned next to the wire. See Figure 1.

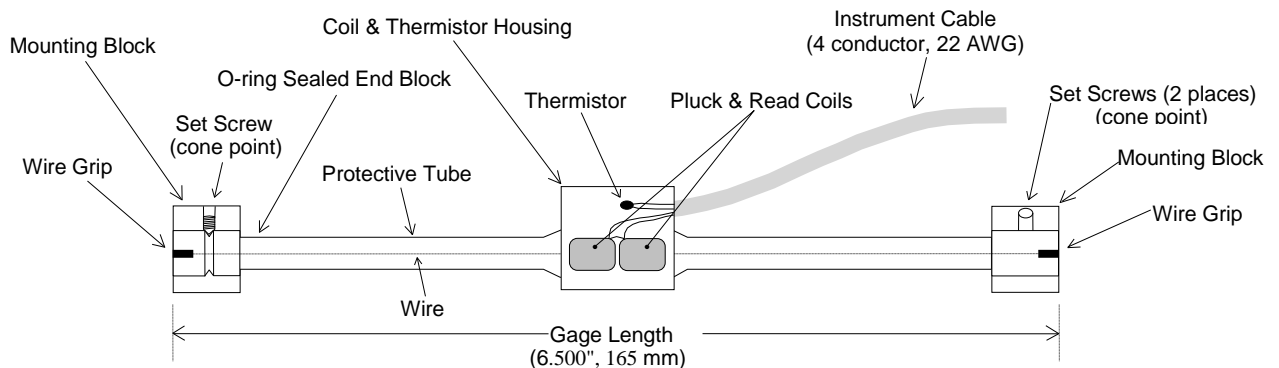

Figure 1 - Model 4000 Vibrating Wire Strain Gage

Portable readouts available from Geokon, used in conjunction with the Vibrating Wire Strain Gage, will provide the necessary excitation to pluck the wire and will convert the measured frequency so as to display the reading directly in microstrain.

This manual contains installation instructions, readout instructions and recommended maintenance and troubleshooting procedures. The theory of the gage is also given, along with some suggestions for data interpretation.

2. GAGE INSTALLATION -GENERAL

2.1 Preliminary Tests

A preliminary check is advisable, and this is made by placing the coil assembly onto the gage and connecting it to the GK-401, GK-402 or GK-403 Readout Box. Switch the position selector to "C" and turn the unit on. While gently pulling on the gage end blocks, observe the reading; it should be seen to increase with increased tension. Do not apply excessive tension, (>10Kgm (20lbs)), as the wire could break. The nominal reading range is 1000 to 4000 microstrain. Mid-range is approximately 2500 microstrain.

Check the resistance between the two lead wires (red and black). It should be around 180 ohms. If the gage contains a thermistor, check its resistance between the white and green lead wires. (The resistance should be around 3000 ohms at 25 degrees C). Check the reading against that which should be obtained at the existing ambient temperature. See [Appendix C](#) for the resistance versus temperature correlation.

Return any faulty gages to the factory. Gages should not be opened in the field.

2.2 Arc Welding the Mounting Blocks to Steel Surfaces – Using the Spacer Bar

The Model 4000 Vibrating Wire Strain Gage is attached to mounting blocks that must first be arc welded to the steel surface to be studied. A spacer bar and spacing jig are used to correctly space apart the two blocks. Figure 2 shows the procedure: the two mounting blocks are fitted over the ends of the spacer bar, and the jig is used to position them correctly, while the set screws in the mounting blocks are tightened down onto the spacer bar. Avoid excessive tightening as this only damages the spacer bar unduly.

The mounting blocks are supplied in pairs; one has a single cone point set-screw, the other has two cone point set-screws.

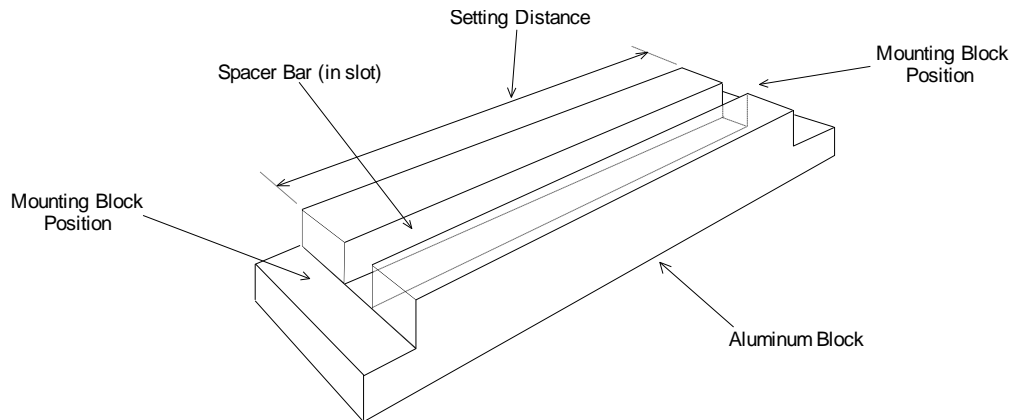

Figure 2 - Spacing Jig

2.3 Arc Welding Sequence

The steel surface is cleaned using a wire brush to remove all scale, rust, dirt and oil. The blocks are then removed from the spacing jig and pressed firmly against the steel surface using the spacer bar as a handle. The edges of the mounting blocks are now welded in the order as shown in Figure 3.

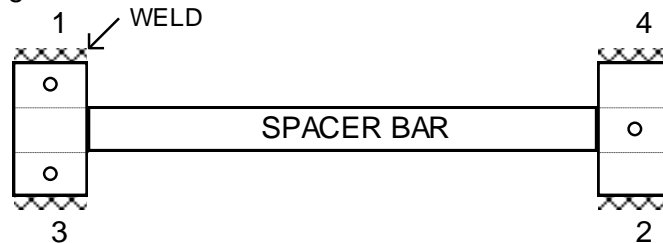

Figure 3 - Welding Sequence for the Mounting Blocks

Avoid excessive heat and DO NOT WELD THE FLAT END SURFACES as this will prevent removal of the spacer bar. Avoid welding splatter which could stick to the spacer bar. **To speed things up, where many gages are being installed, it is advantageous to have more than one spacer bar.**

After welding, cool the mounting blocks with a water-soaked rag, then slacken the set screws and slide out the spacer bar. Clean away all welding slag using a chipping hammer and wire brush. (Optional: Paint over the surface to provide some protection against corrosion).

2.4 Setting the Strain Gage

When the mounting blocks have been welded in place the strain gage can be slid into the holes in the mounting blocks. One end of the strain gage has a V-groove in it - make sure that this end goes inside the mounting block that has the single cone-point set screw. Tighten hard the cone point set screw into the V-groove. Now clip the coil housing around the gage and connect to the readout box (**Channel C**). Set the initial reading on the gage to the correct level depending on whether compressive or tensile strains are anticipated. The useable range of the strain gage runs from around 1000 to 4000 microstrains. The mid-range reading is 2500. The reading can be adjusted by simply pulling or pushing on the free end of the strain gage. Strain gages are shipped with a reading of around 3000 to 3500. This level is OK for compressive strains. If tensile strains are to be measured set the initial reading to around 1500.

When the desired reading has been achieved tighten the two cone-point set screws in the mounting block: tighten hard down onto the end of the strain gage. Tighten the hose clamp onto the coil housing: tighten hard using a nut driver. **Finish off by tapping the mounting blocks with, say, the handle of a screwdriver, to remove any installation strains and stabilize the initial reading. Tap until the reading remains stable**

2.5 Initial Readings

All readings are referred to an initial reading, so **it is important that this initial reading be carefully taken**. Remember to tap the gages as described in section 2.4. It is preferable to install gages on steel members, which are still in an unloaded condition, i.e., prior to their assembly into the structure. In this way, the initial readings correspond to zero load, otherwise, if the member is under load the initial readings will correspond to some unknown load level.

3. GAGE PROTECTION

3.1 Protection from corrosion at the weld points can be inhibited by applying a coat of rust-preventative paint.

3.2 Protection from direct sunlight and rapid changes in ambient temperature is provided best by covering the gages with a layer of insulating material. This can be important because the gage can heat up and cool down much faster than the underlying steel and this can give fairly large spurious readings. The thermal coefficient of expansion of the steel vibrating wire is the same as that for the steel of the structure to which the gage is attached, so that **no temperature correction to the measured strain is required when calculating load induced strains**. However, this is only true if the wire and the underlying steel structure are at the same temperature. If sunlight is allowed to impinge directly onto the gage, then this could elevate the temperature of the wire above the surrounding steel and cause large changes in apparent strain. **Therefore, always shield strain gages from direct sunlight**. Also, avoid excessive handling of the gage prior to taking zero readings. Always allow sufficient time for the gage temperature to stabilize before reading. In any case, it is always a good idea to record the temperature every time the strain reading is made, so that any loads and strains, caused purely by temperature changes, can be assessed. [\(See also Appendix E and G.\)](#) In order to facilitate the measurement of temperature, each strain gage has a thermistor encapsulated along with the plucking coil. The thermistor is connected to the green and white conductors. The GK403 and GK404 readout boxes display the temperature directly in degrees C. An ohmmeter can also be used. [\(The relationship between resistance and temperature is shown in Appendix C\).](#)

3.3 Protection from mechanical damage can be had by using the cover plates made by Geokon. (See Figure 4) Two 3/8 x 2 inch long hex-head bolts which will hold the cover plates should be welded in place hex-head down. The special cover plates are made from sheet steel formed into a channel shape. To get the correct spacing for the bolts a spacer jig is available or the cover plate can be flipped over on its back and the holes in the cover plate used to mark the bolt locations. The holes are spaced at a nominal 21 inches (530mm) apart: one hole is slotted so that the spacing is not critical. Studs should not be positioned within 6 inches of the strain gage and excessive force should not be used when tightening the cover retaining nuts as this will distort the underlying steel surface and can give rise to spurious strain readings. Also avoid welding anywhere near the gage as this also will cause large local distortions of the metal. Either a special stud welder or an arc welder can be used to weld

the head of the 3/8 inch (9mm) hex head bolt to the steel surface. Tighten the two hex nuts that hold the cover plates in place.

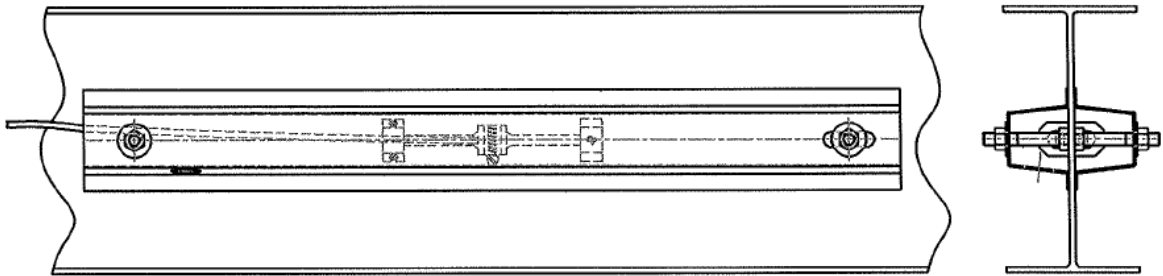

Figure 4 - Typical Cover Plate Installation

3.4 Cable and connector protection

The cable should be protected from accidental damage by moving equipment or fly rock. This is best done by putting the cable inside flex-conduit and by positioning the conduit in as safe a place as possible. Conduit can be connected via conduit bulkhead connectors to the cover plates, (the Geokon cover plate has a knock-out which when punched out provides a hole for connecting the conduit connector), and to a readout enclosure. A typical readout enclosure has a hinged and gasketed cover that keeps the ends of the lead wires and/or plugs clean and dry. Alternatively, if many strain gages are to be read out at the same location, a terminal box may be installed. The front panel inside the terminal box can have a rotary switch or jacks or plug-ins, which facilitate the connection of the numerous gages to the patch cord from the readout box.

Cables may be spliced to lengthen them, without affecting gage readings. Always waterproof the splice completely, preferably using an epoxy based splice kit such the 3M Scotchcast™, model 82-A1.

Cables may be terminated by stripping and tinning and connected to the patch cord from the portable readout box, or a plug may be used which will plug directly into the readout box or into a receptacle on special patch cord.

3.5. Lightning Protection

The Model 4000 Vibrating Wire Strain Gage, unlike numerous other types of instrumentation available from Geokon, does not have any integral lightning protection components, i.e. transorbs or plasma surge arrestors.

Here are a few suggestions;

- If the gage is connected to a terminal box or multiplexer components such as plasma surge arrestors (spark gaps) may be installed in the terminal box/multiplexer to provide a measure of transient protection. Terminal boxes and multiplexers available from Geokon provide locations for installation of these components.
- Lightning arrestor boards and enclosures are available from Geokon that install at the exit point of the instrument cable from the structure being monitored. The enclosure has a removable top so, in the event the protection board (LAB-3) is damaged, the user may service the components (or replace the board). A connection is made between this enclosure and earth ground to facilitate the passing of transients away from the gage. See Figure 5. Consult the factory for additional information on these or alternate lightning protection schemes.
- Plasma surge arrestors can be epoxy potted into the gage cable close to the sensor. A ground strap would connect the surge arrestor to earth ground, either a grounding stake or the steel structure itself.

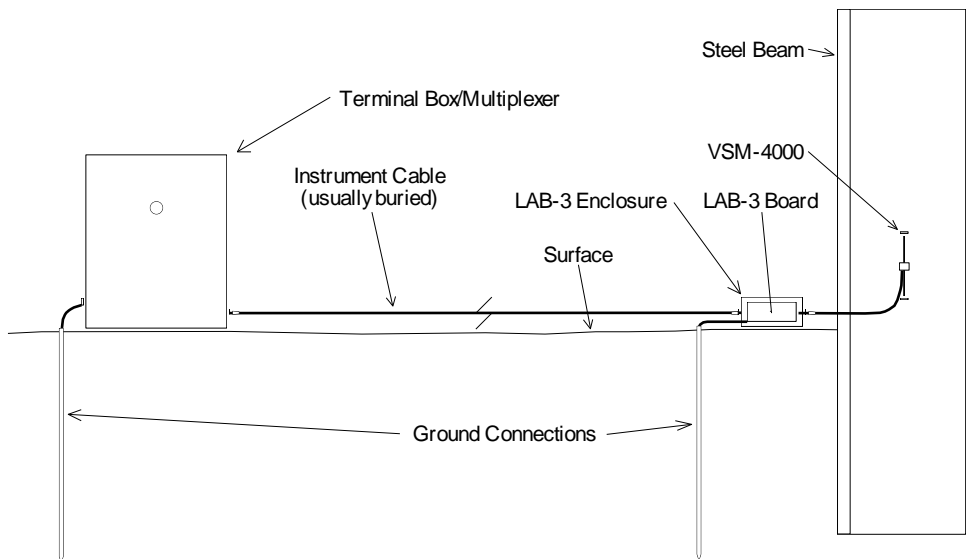

Figure 5 - Lightning Protection Scheme

4. GAGE LOCATION

4.1. End Effects

If end effects are to be avoided then strain gages should be placed away from the ends of struts where they may be influenced by localized clamping or bolting distortions. For most structural members a distance of 5 feet is sufficient. On the other hand, end effects may be of some interest because they add to the load induced effects and may be large enough to initiate failure at the ends rather than in the middle of the structural member.

4.2. Welding Effects

Arc welding close to the gages can cause very large localized strains in the steel member. Thus, welding studs onto soldier piles to support lagging, or shotcrete reinforcing mesh, etc., can cause big strain changes as can welding cover plates or protective channels, etc., over the gages and cables. Always take gage readings before and after any arc welding on the steel structure so that corrections can be applied to any apparent strain shifts.

4.3 Bending Moments

In the case of a steel structure, a strain gage measures the strain at one point on the surface, and this would be sufficient if it could be guaranteed that no bending was occurring in the member. In practice, this will only occur near the center of long thin members subjected to tensile loads. Elsewhere, **bending moments are the rule rather than the exception**, and there will be a neutral axis around which bending takes place.

Since bending effects must be taken into account then more than one strain gage is required at each cross section of the structural member, and for a complete analysis at least three gages are required and very often more. On a **circular pipe strut** three gages spaced 120° apart around the periphery of the strut would suffice. ([See Appendix G](#)). On an **H pile or I beam** at least four strain gages would be called for, and on sheet piling two gages back to back on either side of the pile would be required. (Where a member is subjected to bending and **only the front surface is accessible**, for instance, a steel tunnel lining or the outside of sheet pilings, the bending moments can be measured by installing two vibrating wire gages at different distances from the neutral axis). ([See Appendix H](#)).

Consider the example of an **I-beam** shown in Figure 6A.

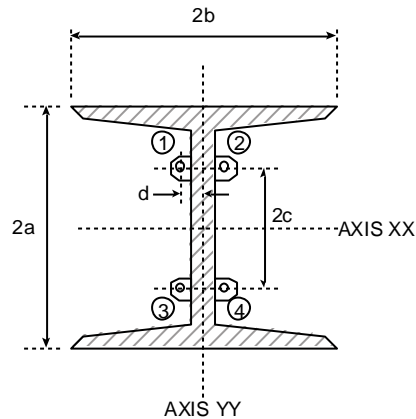

Figure 6A - Strain Gages Mounted on Central Web measures Axial Strain and Bending Moments about both XX and YY Axes

Four strain gages (1, 2, 3 and 4) are welded in two pairs back to back on the central web. The gages are at a height (d) above the center of the web (axis yy) and at a distance ($2c$) apart. The I-beam has a flange ($2b$ wide) and a web ($2a$ deep). The axial stress is given by averaging the strain reading from all four strain gages and multiplying by the modulus.

$$\sigma_{\text{axial}} = \frac{(\varepsilon_1 + \varepsilon_2 + \varepsilon_3 + \varepsilon_4)}{4} \times E$$

Equation 1 - Axial Stress Calculation

The stress due to bending is calculated by looking at the difference between pairs of gages mounted on opposite sides of the neutral axis. Thus the maximum stress due to bending about axis yy is given by:

$$\sigma_{yy} = \frac{(\varepsilon_1 + \varepsilon_3) - (\varepsilon_2 + \varepsilon_4)}{2} \times \frac{b}{d} \times E$$

Equation 2 - Stress due to bending on Axis yy

The maximum stress due to bending about axis xx is given by:

$$\sigma_{xx} = \frac{(\varepsilon_1 + \varepsilon_2) - (\varepsilon_3 + \varepsilon_4)}{2} \times \frac{a}{c} \times E$$

Equation 3 - Stress due to bending on Axis xx

$$\sigma_{\text{maximum}} = \sigma_{\text{axial}} + \sigma_{xx} + \sigma_{yy}$$

Equation 4 - Maximum Stress

In all of the above calculations pay strict regard to the sign of the strain.

Note that the total strain, at any point in the cross section, is the algebraic sum of the bending strains and the axial strain. It will be seen that the strains in the outer corners of the flange can be a lot higher than the strains measured on the web and that failure of the section can be initiated at these points, hence the importance of analyzing the bending moments.

The above consideration would also seem to lead to the conclusion that, from the point of view of obtaining the best measure of the maximum strains, the best location for the strain gages would be on the outer corners of the flanges as shown in Figure 6B. The disadvantage of having the gages located here lies in the difficulty of protecting the gages and cables from accidental damage. But a much more **serious problem** can arise from the fact that **each of the 4 gages can be subjected to localized bending forces which affect only one gage, but not the others**. It is not uncommon for welding to take place at points close to a strain gage and often this produces large strain changes in any strain gage close by. Also it is not uncommon for local blocking (e.g. tunnel arch supports) and the addition of struts to cause strain changes on only a single gage close by.

It is always best to locate gages in pairs, one on either side of the neutral axis of the part of the I beam to which the gage is attached. This is why the configuration of 6A is preferable. There is the added advantage that gages located on the web, as shown in Figure 6A, are much easier to protect.

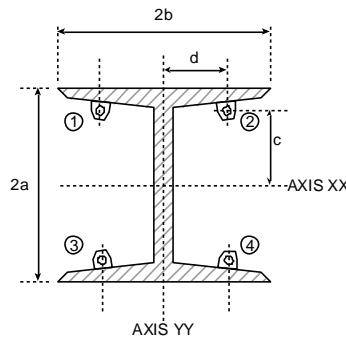

Figure 6B - Strain Gages Mounted on Flanges (Not Recommended on Tunnel Arches)

If, for reasons of economy, it is decided that only two strain gages per cross-section are to be used, then the configuration of figure 6C will give the axial strains and the bending moment around the minor YY axis only.

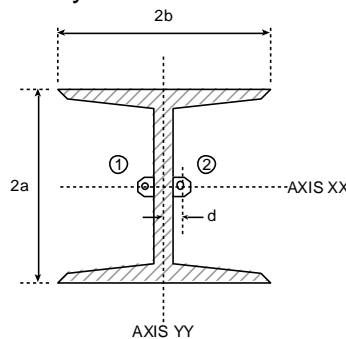

Figure 6C - Axial Strain Measurement and Bending Moment about YY axis only.

This configuration has the advantage of positioning the gages and cables where they are easy to protect. In fact the cable from one gage can be passed through a hole drilled in the web so that both cables can be protected inside a single conduit.

Another configuration of 2 gages that has been used is shown in figure 6D.

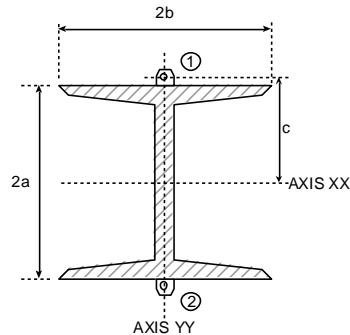

Figure 6D - Axial Strain and Bending Moments about XX axis

This configuration allows the calculation of the axial strains and the bending moment around the major XX axis. A disadvantage lies in the exposed position of the gages on the outside of the flanges which will require a greater degree of protection for the gages and cables. It suffers from the greater disadvantage that local bending at one gage may not be felt by the other gage. For example, in one instance welding on the exposed flange of a soldier pile, close to one gage, produced large strain changes not felt by the other gage on the back side of the pile.

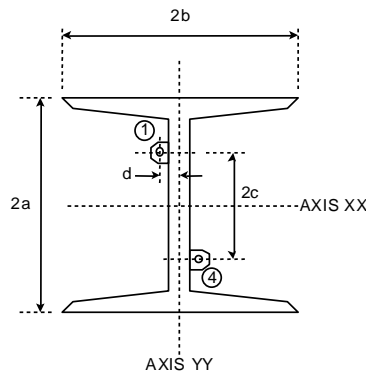

Figure 6E – Axial Strain and Bending Moment around axis XX (Not recommended)

The configuration shown in figure 6E has been used to allow the calculation of the axial strains and also to provide a measure of the bending moment around the major XX axis. But any bending around the minor YY axis will affect the reading to some extent. More importantly, there is the risk that one gage can be affected by local bending without affecting the other gage. This configuration is not recommended

5. SPECIAL APPLICATIONS

5.1 Installation on Driven Steel Piles.

Model 4000 strain gages, and their cables, mounted on steel piles need to be protected from being scraped off as the pile is driven into the ground. Protection is afforded by welding channels or angle iron over the top of the gages and cables as shown in the figure 7 below.

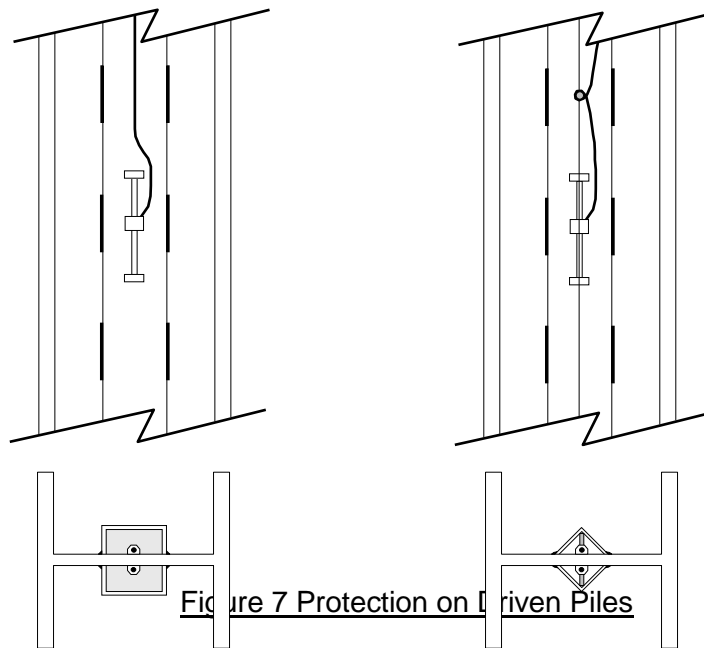

Channels can be made from channel iron, (4" x 1 1/2"), or angles from angle iron, (2 1/2 inch minimum). If possible, channels and angles should be welded before the gages and cables are installed. Leave windows over the gage locations so that the gages can be welded in place. Seal the windows by welding a section of the angle over the window. (Or a plate if channels are used). This will avoid burning the cables. It is not necessary to use continuous welds, Tack welding will do so long as it holds the angles or channels firmly in place. Cables must be restrained by **welding studs at 3 meter intervals** to which the cables can be tied.

In order to prevent shock damage during driving special care must be taken:

- The mounting blocks must be installed so that the upper mounting block is the one with the single set-screw.
- The setscrews holding the gage inside the mounting blocks must be tightened very tight with Loctite on the threads.
- The coil must be glued onto the flat area of the gage tube. (Use any cyanoacrylate product such as Eastman 910 or Crazy Glue). Make sure that the cable side of the coil points towards the top of the pile. i.e., towards the end of the gage with the V-groove.

- As an added precaution, the hose clamp holding the coil onto the gage must be tightened very tight with a nut driver.

5.2 Installation on Steel or Concrete Surfaces using Epoxy Cements.

Geokon strain gages can be epoxied to steel or concrete surfaces if proper care is taken to clean the surfaces to be bonded and if sufficient time is allowed for the epoxy to cure before the gages are attached to the mounting blocks.

5.2.1 Concrete Surfaces:

Materials

Devcon Underwater Putty P/N 11800

Loctite 410 Instant Adhesive P/N 41045

1. Mix a small quantity of the two part underwater epoxy. The ratio is 1/1
2. Grind and/or sand the surfaces to be bonded, (this includes both the concrete and the end block surfaces), and then clean with compressed air or aerosol cleaner.
3. Attach the mounting blocks to the spacer jig, as per section 2.2 above.
4. Apply a thin layer of the premixed underwater epoxy to the center 2/3 rds of the mounting block, (see sketch below).
5. Apply a thin layer of 410 Instant adhesive to the outside edges of the mounting blocks.
6. Press the assembly firmly against the surface and hold in place for 2 minutes.
7. Carefully remove the spacer bar from the mounting blocks.
8. Allow 24 hours curing time before the gages are installed.

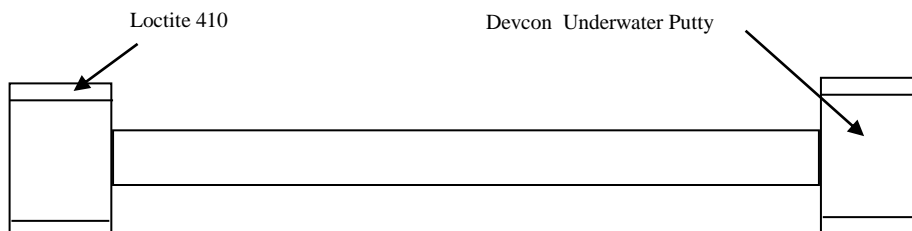

Figure 8 Installation using Epoxy

5.2.2 Steel Surfaces:

Use Loctite Speedbonder H4500. This can be purchased in Cartridge form that automatically dispenses the two-part adhesive in its correct 10/1 mixture. The adhesive sets up to maximum strength in 10 minutes during which time the mounting blocks should be held to the surface using hand pressure, weights or magnets.

5.3 Installation on Concrete Surfaces using anchor studs

Concrete surface strains can be measured utilizing the Model 4000 Vibrating Wire Strain Gage by attaching the strain gage to the concrete surface using the following method:

Grout special stud mounted end blocks, (Part NO 4000-5), into drilled holes in the concrete. A template is available, (Model 4000-11), for drilling two 2½" deep holes in the concrete at the proper spacing. The holes should be a minimum ½" in diameter. The mounting blocks are connected to the spacer bar using the spacer block, ([see section 2.2](#)), to position them properly. The studs are then grouted into the pre-drilled holes using either fast-setting hydraulic cement or a high-strength epoxy. Redhead epoxy, type Epcon Ceramic 6, works well.

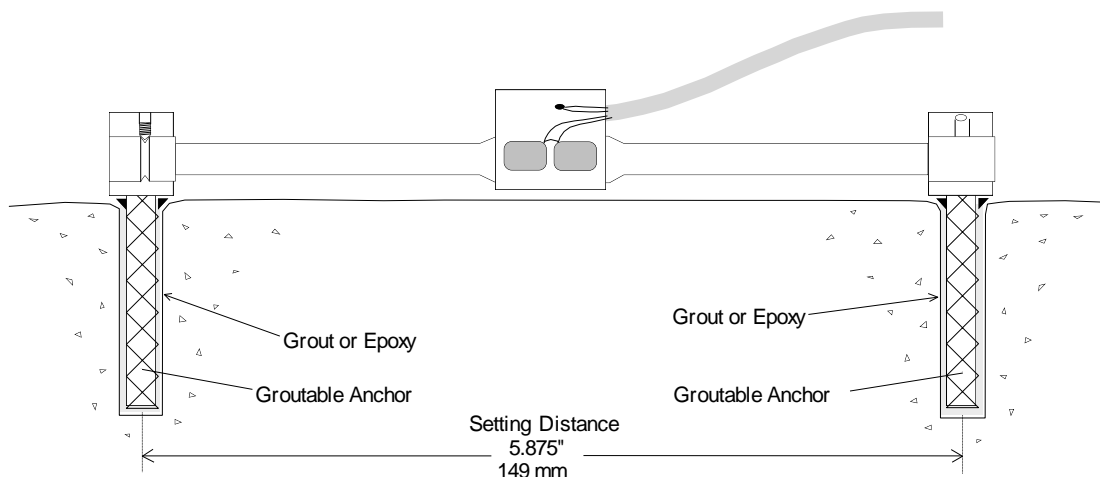

Figure 9 - Installation on Concrete using Groutable Anchors

6. TAKING READINGS

The following three sections describe how to take readings using either of the two readouts available from Geokon.

Model:	4000	4050
Readout Position:	C	B
Display Units:	microstrain ($\mu\epsilon$)	digits ($f^2 \times 10^{-3}$)
Frequency Range:	450-1250 Hz	1400-3200 Hz
Mid-Range Reading:	2500 $\mu\epsilon$	6000 digits
Minimum Reading:	1000 $\mu\epsilon$	2000 digits
Maximum Reading:	4000 $\mu\epsilon$	10000 digits

Table 1 - Strain Gage Readout Strain Ranges

6.1. Operation of the GK-403 Readout Box

The GK-403 can store gage readings and also apply calibration factors to convert readings to engineering units. Consult the GK-403 Instruction Manual for additional information on Mode "G" of the Readout. The GK-403 reads out the thermistor temperature directly in degrees C.

Connect the Readout using the flying leads or in the case of a terminal station, with a connector. The red and black clips are for the vibrating wire gage, the white and green leads are for the thermistor and the blue for the shield drain wire.

1. Turn the display selector to position "C" or "B". See Table 1 for correct position.
2. Turn the unit on and a reading will appear in the front display window. The last digit may change one or two digits while reading. Press the "Store" button to record the value displayed. If the no reading displays or the reading is unstable see section 5 for troubleshooting suggestions. The thermistor will be read and displayed on the screen above the gage reading in degrees centigrade.
3. The unit will automatically turn itself off after approximately 2 minutes to conserve power.

6.2 Operation of the GK-404 Readout Box

The GK404 is a palm sized readout box which displays the Vibrating wire value and the temperature in degrees centigrade.

The GK-404 Vibrating Wire Readout arrives with a patch cord for connecting to the vibrating wire gages. One end will consist of a 5-pin plug for connecting to the respective socket on the bottom of the GK-404 enclosure. The other end will consist of 5 leads terminated with alligator clips. Note the colors of the alligator clips are red, black, green, white and blue. The colors represent the positive vibrating wire gage lead (red), negative vibrating wire gage lead (black), positive thermistor lead (green), negative thermistor lead (white) and transducer cable drain wire (blue). The clips should be connected to their respectively colored leads from the vibrating wire gage cable.

Use the **POS** (Position) button to select position **C** and the **MODE** button to select **μE** (microstrain).

Other functions can be selected as described in the GK404 Manual.

The GK-404 will continue to take measurements and display the readings until the **OFF** button is pushed, or if enabled, when the automatic Power-Off timer shuts the GK-404 off.

The GK-404 continuously monitors the status of the (2) 1.5V AA cells, and when their combined voltage drops to 2V, the message **Batteries Low** is displayed on the screen. A fresh set of 1.5V AA batteries should be installed at this point

6.3 Operation of the GK-405 Readout Box

The GK-405 Vibrating Wire Readout is made up of two components:

- the Readout Unit, consisting of a Windows Mobile handheld PC running the GK-405 Vibrating Wire Readout Application
- the GK-405 Remote Module which is housed in a weather-proof enclosure and connects to the vibrating wire sensor by means of:
 - 1) Flying leads with alligator type clips when the sensor cable terminates in bare wires or,
 - 2) by means of a 10 pin connector..

The two components communicate wirelessly using Bluetooth®, a reliable digital communications protocol. The Readout Unit can operate from the cradle of the Remote Module (see Figure 10) or, if more convenient, can be removed and operated up to 20 meters from the Remote Module



Figure 10 GK405 Readout Unit

For further details consult the GK405 Instruction Manual.

6.4. Measuring Temperatures

All Vibrating Wire Strain Gages are equipped with a thermistor for reading temperature. The thermistor gives a varying resistance output as the temperature changes. Usually the white and green leads are connected to the internal thermistor.

Note: The GK-403 and GK404 readout boxes will read the thermistor automatically and display temperature directly in °C.

7. DATA INTERPRETATION

Readings on Channel C of the GK-401, GK-403 or GK-404 Readout Box are displayed directly in microstrain based on the theoretical equation;

$$\mu\epsilon_{\text{theory}} = 4.062 (f^2 \times 10^{-3})$$

Where $\mu\epsilon$ is the microstrain and f is the resonant frequency of the vibrating wire.

7.1 Conversion of the Readings to Strain Changes

In practice the method of wire clamping effectively shortens the vibrating wire slightly causing it to over-register the strain. This effect is removed by applying a batch gage factor (B) supplied with the gages. (A typical batch gage factor for the Model 4000 strain gage is 0.943 ± 0.01). Then

$$\mu\epsilon_{\text{apparent}} = (R_1 - R_0)B$$

Equation 5 - Apparent Strain Calculation

Where R_0 is the initial reading on Channel C and R_1 is a subsequent reading.

Note: when $(R_1 - R_0)$ is positive, the strain is tensile.

This value of the apparent strain is the one required for computing stresses in equations 2 through 4 on page 8. The stresses thus computed are the total of those caused by both construction activity and by any temperature change that may have occurred.

7.2 Converting Strains to Stresses

Whereas strain gages measure strain or deformation of the structure, the designer is more interested in the structural loads or stresses. This requires a conversion from the measured strains to computed stresses.

Strain changes with time are computed from strain gage readings taken at various times, and by comparison with some initial readings taken at time zero. This initial reading is best taken when the structural member is under no load, i.e., the gages should be mounted while the member is still in the steel yard or warehouse.

This is not always possible and often strain gages are installed on members that are under some existing load so that subsequent strain changes always take off from some unknown datum. However, a technique exists, namely the "Blind Hole Drilling Method" (Photolastic 1977), whereby residual or existing stresses can be measured. The procedure is to cement a strain gage rosette to the surface and then to analyze the strains caused by drilling a short blind hole in the center of the rosette. However, it is a well-known fact that strains can be locked into the steel during its manufacture. (Often, the skin of a rolled-steel structural member is under tension relative to the underlying steel).

Sometimes it is possible, especially where temporary supports are being monitored, to measure the strain in the structural member after the structure has been dismantled. This

no load reading should agree with the initial no load reading if one was obtained. Any lack of agreement would be an indication of gage zero drift although the possibility of some permanent plastic deformation of the member should not be overlooked, particularly where measured strains were high enough to approach the yield point.

Temperatures should be recorded at the time of each reading along with notes concerning the construction activity that is taking place. These data might supply logical reasons for observed changes in the readings.

8. TROUBLESHOOTING

Maintenance and troubleshooting of Model 4000 Vibrating Wire Strain Gages are confined to periodic checks of cable connections and maintenance of terminals. Once installed, the gages are usually inaccessible and remedial action is limited.

Consult the following list of problems and possible solutions should difficulties arise. Consult the factory for additional troubleshooting help.

Symptom: Strain Gage Readings are Unstable

- ✓ Is the readout box position set correctly? If using a datalogger to record readings automatically are the swept frequency excitation settings correct?
- ✓ Is the strain readings outside the specified range (either compressive or tensile) of the instrument? Gage may have become too slack or too tight; inspection of the data might indicate that this is a possibility. Loosen the two oval point set screws in one of the mounting blocks. This will permit the internal spring to re-tension the gage and the gage will read again. Set the gage to some new datum and retighten the setscrews. If the gage does not respond to re-setting and if the old plucking coil will pluck a new gage, then the gage should be replaced.
- ✓ Is there a source of electrical noise nearby? Most probable sources of electrical noise are motors, generators and antennas. Move the equipment away from the installation or install electronic filtering. Make sure the shield drain wire is connected to ground whether using a portable readout or datalogger.
- ✓ Does the readout work with another gage? If not, the readout may have a low battery or be malfunctioning.

Symptom: Strain Gage Fails to Read

- ✓ Is the cable cut or crushed? This can be checked with an ohmmeter. Nominal resistance between the two gage leads (usually red and black leads) is 180Ω , $\pm 10\Omega$. Remember to add cable resistance when checking (22 AWG stranded copper leads are approximately $14.7\Omega/1000'$ or $48.5\Omega/\text{km}$, multiply by 2 for both directions). If the resistance reads infinite, or very high (megohms), a cut wire must be suspected. If the resistance reads very low ($<100\Omega$) a short in the cable is likely. Splicing kits and instructions are available from the factory to repair broken or shorted cables. Consult the factory for additional information.
- ✓ Does the readout or datalogger work with another strain gage? If not, the readout or datalogger may be malfunctioning.

APPENDIX A - SPECIFICATIONS

	Model 4000	Model 4050
Range (FS), (nominal):	3000 $\mu\epsilon$	3000 $\mu\epsilon$
Resolution:	1.0 $\mu\epsilon$	1.0 $\mu\epsilon$
Accuracy ¹ :	Batch Calibration...+/- 0.5% FS Individual Calibration....+/- 0.1% FS	Batch Calibration...+/- 0.5% FS Individual Calibration....+/- 0.1% FS
Zero Stability:	0.02% FS/yr	0.02% FS/yr
Linearity:	+/- 0.5% FS	+/- 0.5% FS
Thermal Coefficient:	12.2 $\mu\epsilon/^\circ\text{C}$	12.2 $\mu\epsilon/^\circ\text{C}$
Dimensions (gage):	6.5 " long \times 0.50"	12.625" \times 0.50"
(Length \times Diameter)	165 \times 12.5 mm	321 \times 12.5 mm
Dimensions (end blocks)	1" \times 7/8"	1" \times 7/8"
(Width \times Height)	25 \times 22 mm	25 \times 22 mm
Dimensions (coil):	0.875 \times 0.875" 22 \times 22 mm	Internal
Frequency Range:	450 – 1250 Hz	1400 – 3200 Hz
Coil Resistance:	180 Ω	50 Ω
Temperature Range:	-20 to +80° C	-20 to +80° C

Notes:

¹ Using curve fitting techniques, (second order polynomial).

A.2 Thermistor (see [Appendix C](#) also)

Range: -80 to +150° C

Accuracy: $\pm 0.5^\circ\text{C}$

APPENDIX B - THEORY OF OPERATION

A vibrating wire attached to the surface of a deforming body will deform in a like manner. The deformations alter the tension of the wire and hence also its natural frequency of vibration (resonance). The relationship between frequency (period) and deformation (strain) is described as follows;

1. The fundamental frequency (resonant frequency) of vibration of a wire is related to its tension, length and mass by the equation:

$$f = \frac{1}{2L_w} \sqrt{\frac{F}{m}}$$

Where;

L_w is the length of the wire in inches.

F is the wire tension in pounds.

m is the mass of the wire per unit length (pounds, sec.²/in.²).

2. Note that:

$$m = \frac{W}{L_w g}$$

Where;

W is the weight of L_w inches of wire (pounds).

g is the acceleration of gravity (386 in./sec.²).

3. and:

$$W = \rho a L_w$$

Where;

ρ is the wire material density (0.283 lb./in.³).

a is the cross sectional area of the wire (in.²).

4. Combining equations 1, 2 and 3 gives:

$$f = \frac{1}{2L_w} \sqrt{\frac{Fg}{\rho a}}$$

5. Note that the tension (F) can be expressed in terms of strain, e.g.:

$$F = \epsilon_w E a$$

Where;

ϵ_w is the wire strain (in./in.).

E is the Young's Modulus of the wire (30 x 10⁶ Psi).

6. Combining equations 4 and 5 gives:

$$f = \frac{1}{2L_w} \sqrt{\frac{\epsilon_w E g}{\rho}}$$

7. Substituting the given values for E, g and ρ yields:

$$f = \frac{101142}{L_w} \sqrt{\epsilon_w}$$

8. On channel 'A', which displays the period of vibration, T, multiplied by a factor of 10^6 ;

$$T = \frac{10^6}{f}$$

9. Combining equations 7 and 8 gives:

$$\epsilon_w = \frac{97.75 L_w^2}{T^2}$$

10. Equation 9 must now be expressed in terms of the strain in the surface of the body to which the gage is attached. Since the deformation of the body must equal the deformation of the wire:

$$\epsilon_w L_w = \epsilon L_g$$

Where;

ϵ is the strain in the body.

L_g is the gage length (in inches).

11. Combining equations 9 and 10 gives:

$$\epsilon = \frac{97.75}{T^2} \cdot \frac{L_w^3}{L_g}$$

Where; (for the Model 4000 Strain Gage)

L_w is 6.250 inches.

L_g is 5.875 inches.

12. Therefore:

$$\epsilon = 4.062 \times 10^3 \left[\frac{1}{T^2} \right]$$

(Note that T is in seconds $\times 10^6$ and ϵ is in inches per inch)

13. The display on position "C" of the GK-401/403 Readout is based on the equation:

$$\mu\epsilon = 4.062 \times 10^9 \left[\frac{1}{T^2} \right]$$

Note that in this formula ϵ is in micro inches per inch and T is in seconds $\times 10^6$

Alternatively $\epsilon = 4.062 \times 10^{-3} f^2$ microstrain. Where f is the frequency in Hz

The squaring, inverting and multiplication by the factor, 4.062×10^9 , is all done internally by the microprocessor so that the displayed reading on Channel C is given in terms of microinches/inch ($\mu\epsilon$).

APPENDIX C - THERMISTOR TEMPERATURE DERIVATION

Thermistor Type: YSI 44005, Dale #1C3001-B3, Alpha #13A3001-B3

Resistance to Temperature Equation:

$$T = \frac{1}{A + B(\ln R) + C(\ln R)^3} - 273.2$$

Equation C-1 Convert Thermistor Resistance to Temperature

where: T = Temperature in °C.

LnR = Natural Log of Thermistor Resistance

A = 1.4051 × 10⁻³ (coefficients calculated over the -50 to +150° C. span)

B = 2.369 × 10⁻⁴

C = 1.019 × 10⁻⁷

Ohms	Temp	Ohms	Temp	Ohms	Temp	Ohms	Temp	Ohms	Temp
201.1K	-50	16.60K	-10	2417	+30	525.4	+70	153.2	+110
187.3K	-49	15.72K	-9	2317	31	507.8	71	149.0	111
174.5K	-48	14.90K	-8	2221	32	490.9	72	145.0	112
162.7K	-47	14.12K	-7	2130	33	474.7	73	141.1	113
151.7K	-46	13.39K	-6	2042	34	459.0	74	137.2	114
141.6K	-45	12.70K	-5	1959	35	444.0	75	133.6	115
132.2K	-44	12.05K	-4	1880	36	429.5	76	130.0	116
123.5K	-43	11.44K	-3	1805	37	415.6	77	126.5	117
115.4K	-42	10.86K	-2	1733	38	402.2	78	123.2	118
107.9K	-41	10.31K	-1	1664	39	389.3	79	119.9	119
101.0K	-40	9796	0	1598	40	376.9	80	116.8	120
94.48K	-39	9310	+1	1535	41	364.9	81	113.8	121
88.46K	-38	8851	2	1475	42	353.4	82	110.8	122
82.87K	-37	8417	3	1418	43	342.2	83	107.9	123
77.66K	-36	8006	4	1363	44	331.5	84	105.2	124
72.81K	-35	7618	5	1310	45	321.2	85	102.5	125
68.30K	-34	7252	6	1260	46	311.3	86	99.9	126
64.09K	-33	6905	7	1212	47	301.7	87	97.3	127
60.17K	-32	6576	8	1167	48	292.4	88	94.9	128
56.51K	-31	6265	9	1123	49	283.5	89	92.5	129
53.10K	-30	5971	10	1081	50	274.9	90	90.2	130
49.91K	-29	5692	11	1040	51	266.6	91	87.9	131
46.94K	-28	5427	12	1002	52	258.6	92	85.7	132
44.16K	-27	5177	13	965.0	53	250.9	93	83.6	133
41.56K	-26	4939	14	929.6	54	243.4	94	81.6	134
39.13K	-25	4714	15	895.8	55	236.2	95	79.6	135
36.86K	-24	4500	16	863.3	56	229.3	96	77.6	136
34.73K	-23	4297	17	832.2	57	222.6	97	75.8	137
32.74K	-22	4105	18	802.3	58	216.1	98	73.9	138
30.87K	-21	3922	19	773.7	59	209.8	99	72.2	139
29.13K	-20	3748	20	746.3	60	203.8	100	70.4	140
27.49K	-19	3583	21	719.9	61	197.9	101	68.8	141
25.95K	-18	3426	22	694.7	62	192.2	102	67.1	142
24.51K	-17	3277	23	670.4	63	186.8	103	65.5	143
23.16K	-16	3135	24	647.1	64	181.5	104	64.0	144
21.89K	-15	3000	25	624.7	65	176.4	105	62.5	145
20.70K	-14	2872	26	603.3	66	171.4	106	61.1	146
19.58K	-13	2750	27	582.6	67	166.7	107	59.6	147
18.52K	-12	2633	28	562.8	68	162.0	108	58.3	148
17.53K	-11	2523	29	543.7	69	157.6	109	56.8	149
								55.6	150

Table C-1 Thermistor Resistance versus Temperature

APPENDIX D - MODEL 4050 SPECIAL INSTRUCTIONS (12" GAGE LENGTH)

The Model 4050 Vibrating Wire Strain Gage is a modified version of the Model 4000 Strain Gage designed for measuring strains over a longer base.

The Model 4000 Instruction Manual, Section 2 is applicable, however, note the following special instructions when using the Model 4050.

- The Model 4050 uses a special spacer bar 12 5/8" in length.
- Before installation of the gage, remove the black protective washer trapped between the tube and end-block with the 'V' groove.
- The Model 4050 is read on **Channel B** of the GK-401 and GK-403 Readouts. To set the gage for all-tension the reading should be approximately 2000; for all-compression, 10000; for mid-range set to 6000. Note: if a CR10 is being used the excitation range 1400 – 3500 Hz should be selected.
- To set the gage pull or push on the end of the gage tube where the cable exits (not the cable itself!).
- Convert the position B reading to microstrain using the individual calibration factor (expressed in terms of microstrain/digit) supplied with the instrument.

$$\text{Microstrain } (\mu\epsilon) = (R_1 - R_0)GF$$

- To correct for temperature effects, for the gage only, the following equation is used.

$$\text{Microstrain } (\mu\epsilon) = (R_1 - R_0)GF + (T_1 - T_0)K$$

R_1 = current reading (position B)

R_0 = initial reading (position B)

T_1 = current temperature (°C)

T_0 = initial temperature (°C)

K = +12.0 microstrain/°C

Note: If the gage is attached to steel the net thermal effect is practically zero. If mounted on concrete, use a K factor of +2 microstrain/°C

- **Other gages lengths are possible with the Model 4050. Consult the factory for additional information.**

APPENDIX E - MEASUREMENT OF, AND CORRECTION FOR, TEMPERATURE EFFECTS

If the ends of the structural member were free to expand or contract without restraint then strain changes would take place without any change in stress. And in these situations the strain gage would indeed show no change in reading. Conversely, if the ends of a steel structural member were restrained by some semi-rigid medium, then any increase in temperature of the structural member would result in a build-up of compressive strain in the member, even though the actual strain would be tensile!

The magnitude of this temperature-induced compressive stress increase would be measured accurately by the strain gage, because, while the member is restrained from expansion, the vibrating wire is not restrained and the expansion of the wire would cause a reduction in wire tension and a resulting decrease in the vibration frequency. This would be indicated by a decrease in strain reading on the readout box, corresponding to an apparent increase in compressive stress, which is, *mirabile dictu*, exactly equal to the temperature-induced increase in compressive stress in the member.)

The temperature-induced stresses can be separated from the load-induced stresses by reading both the strain and temperature of the strain gages at frequent intervals over a period of time in which the external loading from construction activity can be assumed to be constant. When these strain changes are plotted against the corresponding temperature changes, the resulting graph shows a straight-line relationship the slope of which yields a factor K_T . This factor can be used to calculate the temperature-induced stress

$$\sigma_{thermal} = K_T (T_1 - T_0)E \dots \dots \dots E1$$

Which if desired can be subtracted from the observed apparent stress change

$$\sigma_{apparent} = (R_1 - R_0)BE \dots \dots \dots E2$$

to give that part of the stress change due to construction activity loads only

$$\sigma_{load} = [(R_1 - R_0)B - K_T (T_1 - T_0)]E \dots \dots \dots E3$$

Note that the correction factor, K_T , may change with time and with construction activity due to the fact that the rigidity of the restraint may change. It would then be a good idea to repeat the above procedure in order to calculate a new temperature correction factor.

If, for whatever reason, the actual strain of the steel member is required, that is, the change of unit length that would be measured by, say, a dial gage attached to the surface, this is given by the equation

$$\mu\epsilon_{actual} = (R_1 - R_0)B + (T_1 - T_0) \times CF_1 \dots \dots \dots E4$$

Where CF_1 represents the coefficient of expansion of steel = +12.2 microstrain/°C.

APPENDIX F - TEMPERATURE CORRECTION WHEN USED ON CONCRETE

In a free field, where no loads are acting, the thermal concrete strains are given by the following equation;

$$\mu\varepsilon_{thermal} = (T_1 - T_0) \times CF_2 \dots\dots\dots G1$$

CF₂ represents the coefficient of expansion of concrete. Unless this figure is known, assume a nominal value of +10.4 microstrain/°C.

If, for whatever reason, the actual strain of the concrete member is required, that is, the change of unit length that would be measured by, say, a dial gage attached to the surface, this is given by the equation

$$\mu\varepsilon_{actual} = (R_1 - R_0)B + (T_1 - T_0) \times CF_1 \dots\dots\dots G2$$

Where CF₁ represents the coefficient of expansion of steel = +12.2 microstrain/°C, and (R₁-R₀)B is the apparent strain recorded by the readout box,

To calculate the strain in the concrete due to load changes only;

$$\mu\varepsilon_{load} = \mu\varepsilon_{actual} - \mu\varepsilon_{thermal} = (R_1 - R_0)B + (T_1 - T_0) \times (CF_1 - CF_2) \dots\dots\dots G3$$

Note the following example, where B = 0.91

R₀ = 3000 microstrain, T₀ = 20°C

R₁ = 2900 microstrain, T₁ = 30°C

$$\mu\varepsilon_{apparent} = (2900 - 3000) \times 0.91 = -91(\text{compressive})$$

$$\mu\varepsilon_{actual} = (2900 - 3000) \times 0.91 + (30 - 20) \times 12.2 = +31(\text{tensile})$$

$$\mu\varepsilon_{thermal} = (30 - 20) \times 10.4 = +104(\text{tensile})$$

$$\mu\varepsilon_{load} = (2900 - 3000) \times 0.91 + (30 - 20) \times (12.2 - 10.4) = -73(\text{compressive})$$

Note: Since assumptions have been made regarding the thermal coefficients for the concrete these equations should only be used as a general guide.

APPENDIX G - CALCULATION OF AXIAL LOADS AND BENDING STRAINS FROM THREE STRAIN GAGES, AT 60 DEGREES, ON A CIRCULAR PIPE

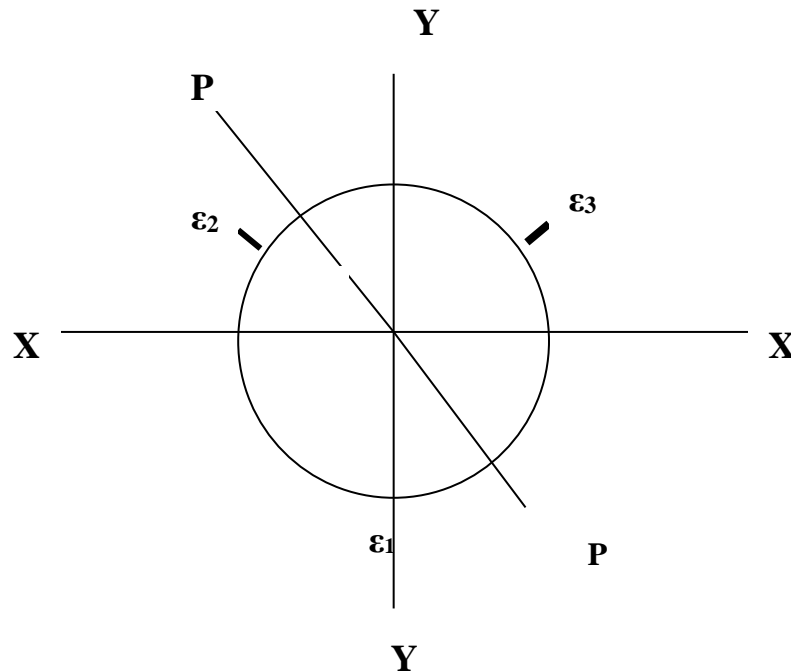

Average Axial Strain $A = (\epsilon_1 + \epsilon_2 + \epsilon_3)/3$

Maximum Bending Strain around the YY Axis, (X) = $\pm [(\epsilon_2 - \epsilon_3)/1.732]$

Maximum Bending Strain around the XX Axis, (Y) = $\pm [((\epsilon_1 + \epsilon_2 + \epsilon_3)/3) - \epsilon_1]$

The maximum strain, P, = $\pm [X\cos\theta + Y\sin\theta] + A$ and $\tan\theta = Y/X$

Example:

Let $\epsilon_1 = 20$, $\epsilon_2 = 192$ and $\epsilon_3 = 88$ (all tensile strains)

Average Axial Strain, $A = (20 + 192 + 88)/3 = +100$ microstrain tension

$X = \pm (104/1.732) = \pm 60$

$Y = \pm (300/3 - 20) = \pm 80$

$\tan\theta = 80/60 = 1.333$ and $\theta = 53$ degrees from the X axis

$P = \pm [60 \times 0.60 + 80 \times 0.8] + 100 = +200$ microstrain. tensile. (and +0 microstrain minimum)

APPENDIX H - TWO STRAIN GAGES MOUNTED ONE ABOVE THE OTHER

Where only one surface of the straining member is accessible then two strain gages can be used one mounted above the other, to separate axial strains from strains due to bending.

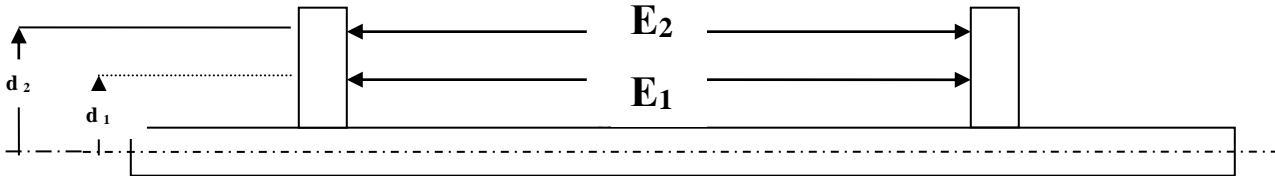

E_1 and E_2 are two measured strains at distances d_1 and d_2 from the neutral axis of a steel member (e.g. a sheet pile)

If $R = d_2/d_1$

· The Axial Strain along the neutral axis = $(RE_1 - E_2)/(R-1)$

The Bending Strain at a distance d_1 from the neutral axis = $(E_2 - E_1)/(R-1)$